

Techno-sociological Challenges and Opportunities for Water Efficiency



Dr Rizwan Nawaz

Research Officer, University of Leeds

Driver	Influencing Factors
Population	Growth, migration, development
Household structure	Ethnicity, housing, planning
Household affluence	Appliance numbers
Cost of water	Tariffs, metering
Water using technology	Consumer regulations
House type	Building regulations
Garden	Size, house type
Knowledge	Education
Climate	Global warming

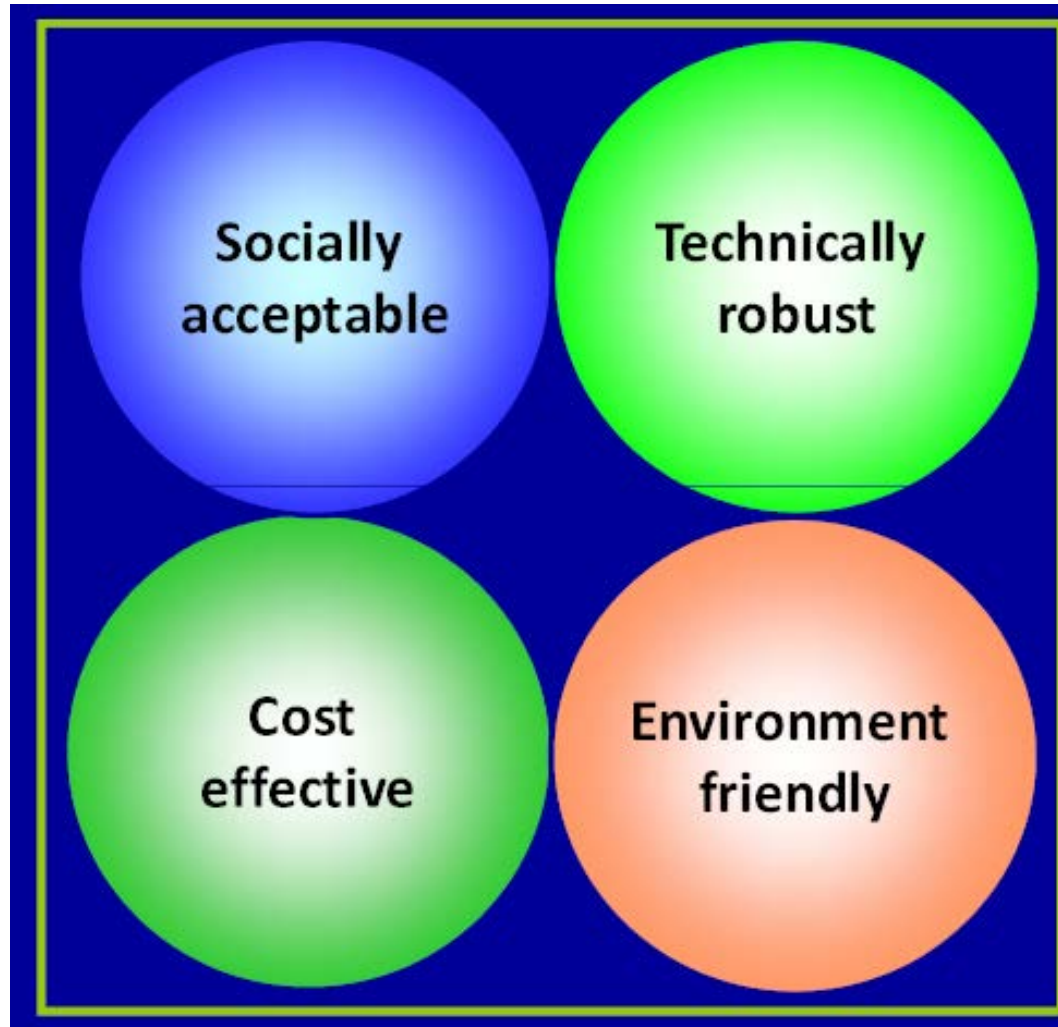

Location	Year(s)	Reduction in Demand	
		average	peak
Four Major Studies			
Fylde	1970/1-1971/2	11-14.5%	-
Mansfield & Malvern	1976	12.5% (range: 8-17%)	-
Isle of Wight	1988/9-1991/2	21.3% (19.1%-23.5%)	-
National Metering Trials: 11[9] sites (s.) in England	1988/9-1991/2	11% (-2%/17%) [11sites] 12% (7%/17%) [9sites]	aver.P7D [11sites]: 18%/27% (wet/dry years)
Other Studies			
Anglian Water (SODCON)	1995	'around 15% – 20%'	P7D: 25% to 35%
WRc: 11 UM & 8 M DMAs	1994-96	-	PHR/DR/WRs: ↓ by 16%/13%/10%
Mid-Kent: Oaks Park)Canter-	1993-96	26% (Acorn group J)	3Q (1995): 50%
Mid-Kent: St. Peters)bury	1993-96	14% (Acorn group C)	3Q (1995): 32%
Two Chelmsford areas	1994-95	-	PDR:25%;PWR:26%
F/stone/Dover: 4 retmt.areas	Jan-Aug 1995	-	PWR: 44%/32%
NERA optants only:			
I (5 WCos.)	7/1996 – 12/2001	9%, ↑ to 11% after 1 yr ⁺	PM:16%; PQtr.:13% [*]
II (3 WCos.)	7/1995 – 6/2002	2-4%, ↑to 8-9% after 3yrs ⁺	-

Abbreviations: UM: unmetered; DMAs: District Metering Areas; P7D: Peak 7-day Demand M: metered + vol.charging; PM: Peak Month Demand (Aug) PHR/DR/WR: Peak Hour/Day/Week Ratios; PQtr: June-August Demand. *estimates.at aver. real vol. charge of £1.60/m³ (Jan.2000 prices)



Water Saving Technology	Number of Studies	Average water saving (litres/property/day)
Toilets		
Cistern displacement devices	16	12
Dual flush toilet	2	103
Dudley Turbo 88	6	16
ecoBETA	8	21
Ecoflush	2	20
Variflush	3	23
Shower & Bath		
Shower timer	8	4
Shower flow restrictor	1	6
Showerheads	11	12
Bath measure	1	4
Replacing bathing with showering	2	38
Taps		
Tap inserts and restrictors	9	10
Tap washers	5	8
Turning tap off when brushing teeth	4	22
Outdoor		
Water butts	4	3
Hose gun	8	1
Soil crystals	1	0.02
Plumbing		
Fixed external leaks	1	12
Float valve repair	1	34

Long Term Savings??

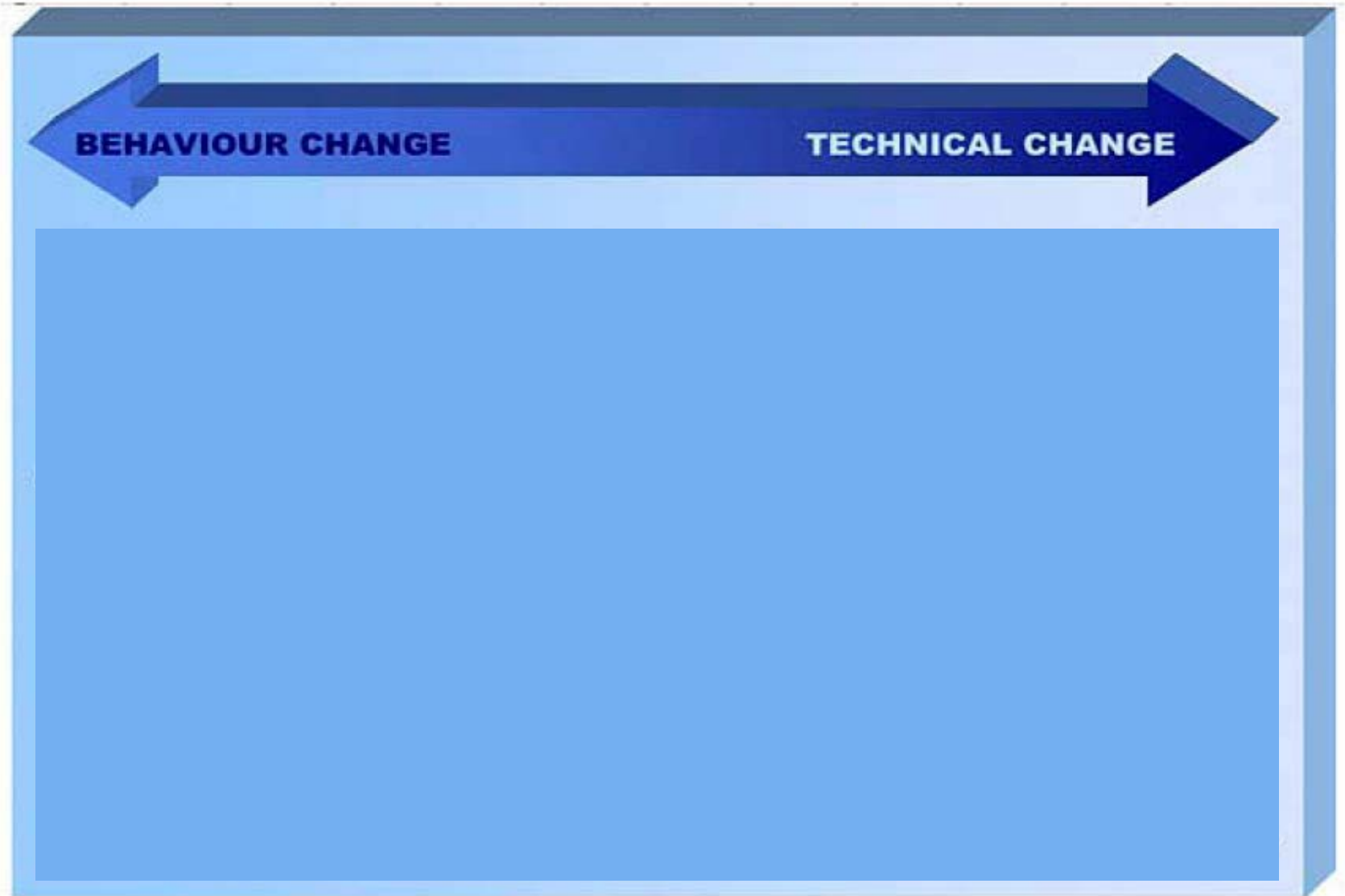



Water Use Behaviours:

‘Efficiency’ behaviours

‘Curtailment’ behaviours

Example 1

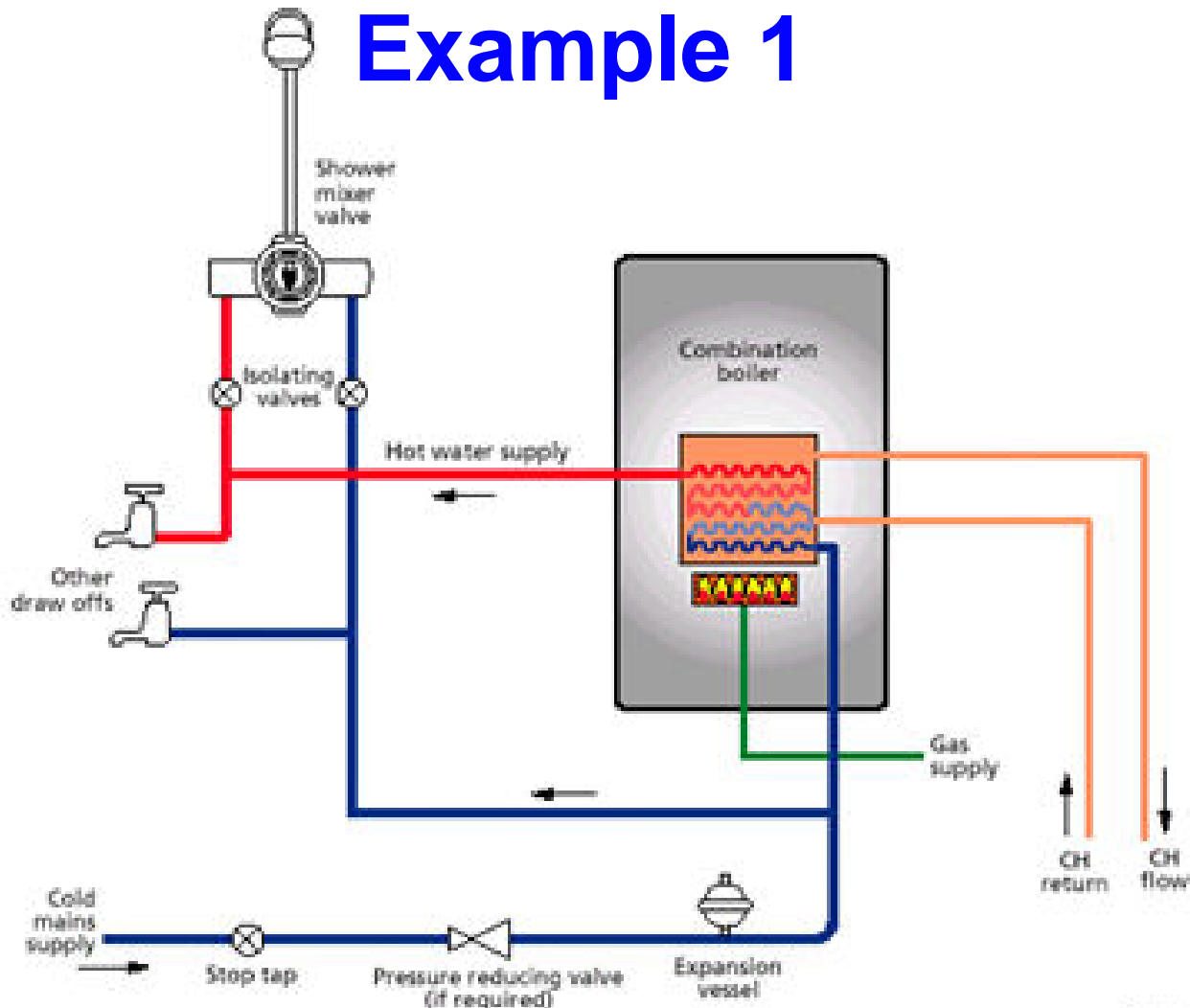

Combi boiler system

Examples

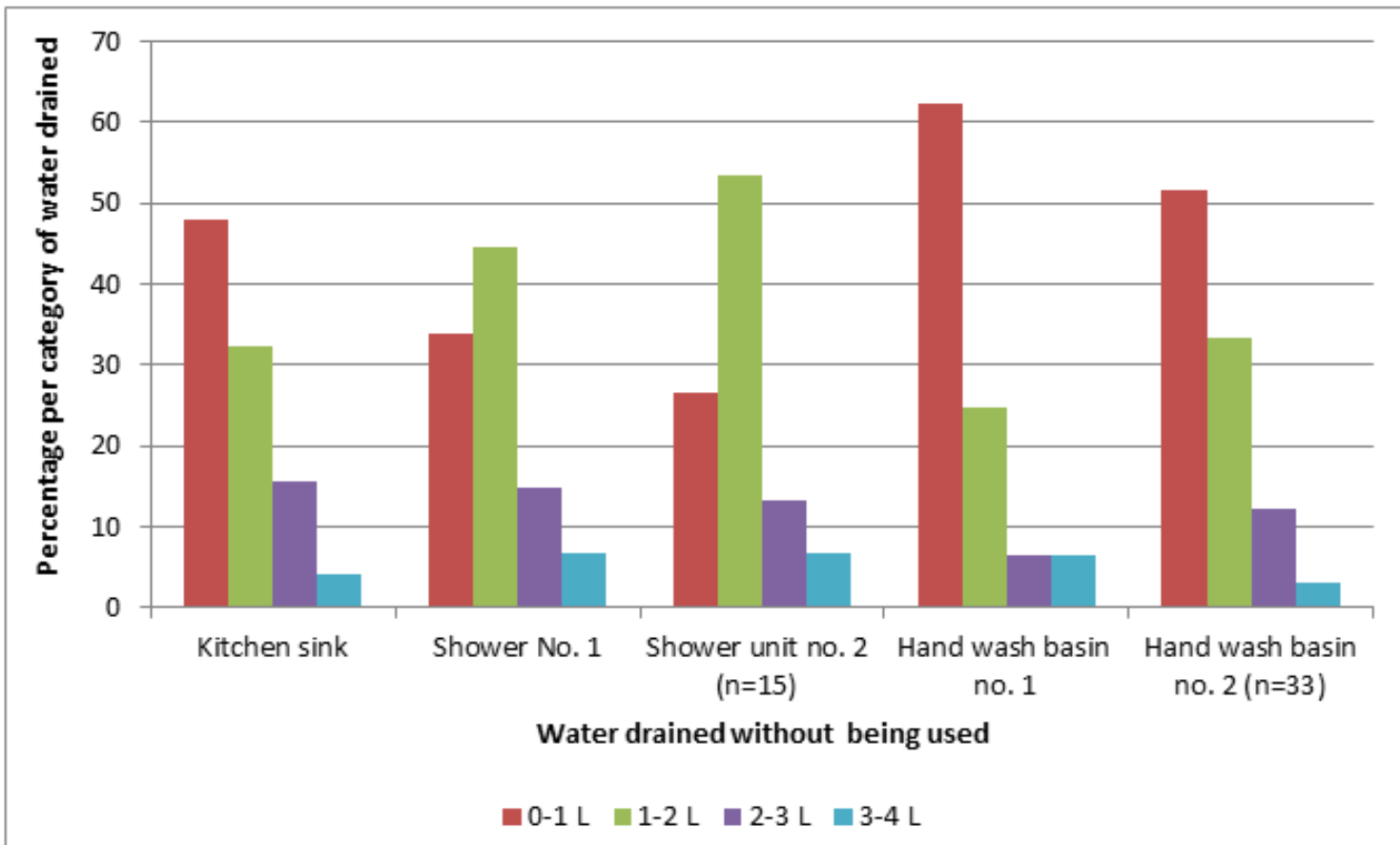

Example 2

% Of Population Of Minority Ethnic Origin By Postal Area

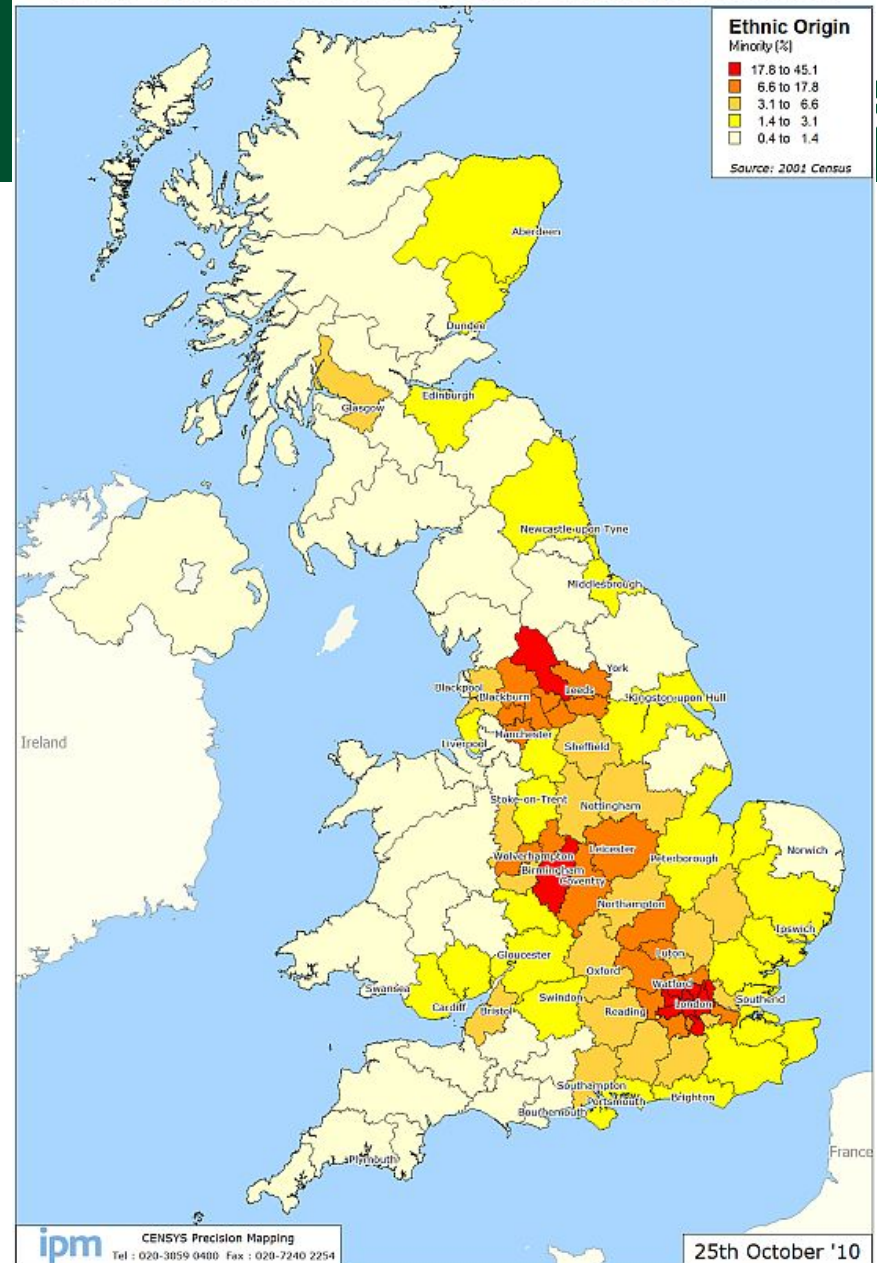



Many faiths consider that the purity of water is transmitted to humankind and cleanses them of contamination through the ablutions that are required of the faithful.....the message could not be clearer: it is essential to preserve that purity, to make use of water with discernment and share it equitably.

Example 3: User Engagement

Breakdown of Desalinated Water Consumption in Abu Dhabi

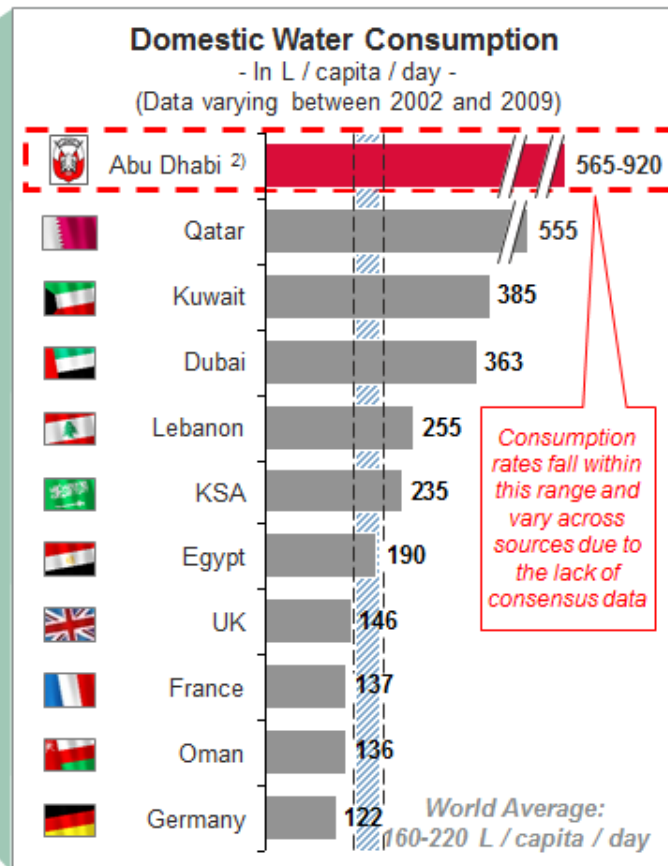
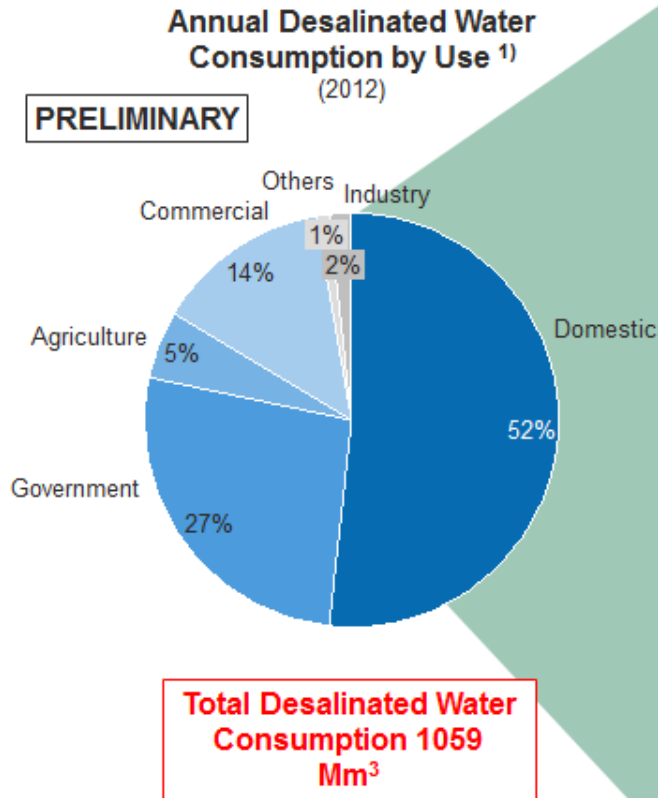

Comments

- Domestic activities account for 52% of desalinated water consumption
- In fact, Abu Dhabi exhibits one of the highest per capita domestic consumption rates in the world varying between 565 and 920 L / capita / day
- Abu Dhabi's high consumption per capita is driven by high indoor water consumption and further exacerbated by outdoor consumption (i.e., car washing, gardening, swimming pools, etc.)

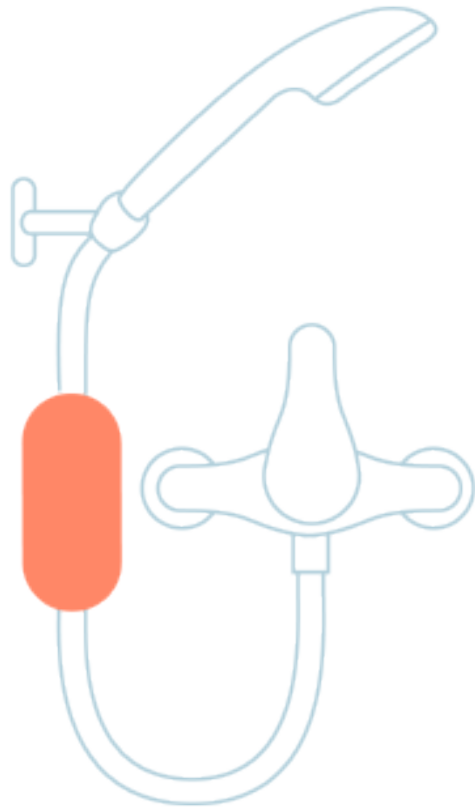



Nawaz NR; Waya BCK (2013) [Estimating the amount of cold water wastage in UK households](#), *Proceedings of the ICE - Water Management*, **167**, pp.457-466. [doi: 10.1680/wama.12.00109](#)

Nawaz, N.R., Lovett, J. and Tompkins, J. (2014) Multi faith and water efficiency communication – a methodological approach. Policy Brief No. ULWW01, University of Leeds and Waterwise

http://www.waterwise.org.uk/data/Multi-Faith_and_Water_Policy_Brief.pdf



Thank you

Rizwan Nawaz

n.r.nawaz@leeds.ac.uk

